

RoHS

本产品符合我司QA-3-04-005
环境管理物质标准规范

包装图

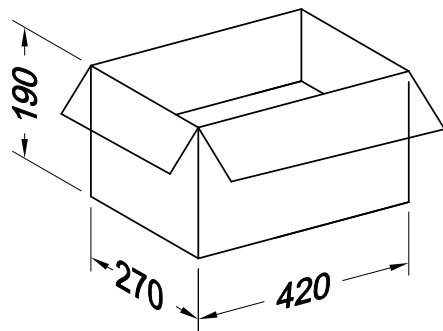
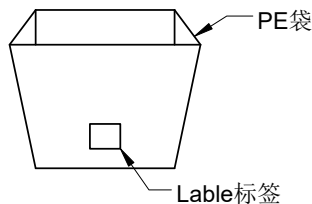

胶带ADHESIVE TAPE

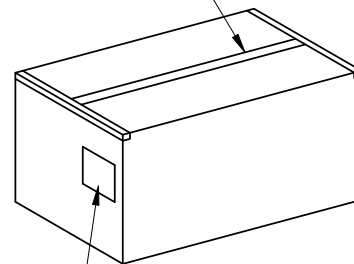

标签LABEL

Note注解:

1. Place Housing into PE bag and seal PE bag. Label.
将 Housing放入PE袋内, 并将PE袋封好.贴上标签.
2. Put PE bag packed products in cartons, Packing detail see the table below
将装好产品的PE袋放入纸箱内, 详细包装见下表
3. Label depends on customer request, carton opening joint with transparent tape
标签依客户要求而定, 纸箱开口处用透明胶带贴合.
4. There shall be no dirt such as deformation phenomenon, Mantissa box fillers must be used
每箱不可有脏污,变形现象,尾数箱必须用填充物
5. Carton material: K=K, Carton thickness: 6~7mm
纸箱材质:K=K, 纸箱厚度: 6~7mm

PIN数	PE袋PE Bag		纸箱Carton		合计Total
	PCS/PE PCS/袋	Bag/Carton 袋/箱	尺寸Size(cm)		
2*08	1000	32	42*27*19		32,000
2*10	1000	30	42*27*19		30,000
2*12	1000	28	42*27*19		28,000
2*13	1000	26	42*27*19		26,000
2*14	1000	24	42*27*19		24,000
2*15	1000	22	42*27*19		22,000
2*20	1000	14	42*27*19		14,000
2*25	1000	8	42*27*19		8,000

日期	版次	变更编号	变更内容说明	变更人	核准

一般公差
.X ±0.35
.XX ±0.25
.XXX ±0.15
X° ±0.2°
视角



东莞市思索连接器有限公司
SWB CONNECTORS CO.,LTD

核准	审查	制作	日期
		马莉	2021/02/27

料号: 1038H-2*XX-N0HF				
名称: 1.00mm Housing Packing				
单位	比例	页次	版本	编号
mm	1:1	1/1	A	A-000

RoHS

本产品符合我司QA-3-04-005
环境管理物质标准规范

包装图

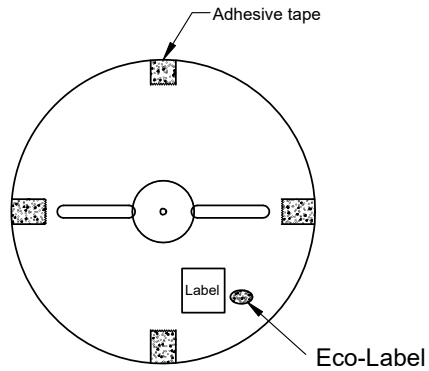

Note注解:

- Quantity数量:
15K PCS/REEL 一卷15K/PCS
10REEL/BOX 一箱10卷
150K PCS/BOX 一箱150K/PCS
- Each reel and outer box must be labeled and Eco-Label Respectively labeled
每盘和外箱都必须有标签及环保标签分别标示
- Terminal winding direction as shown
端子缠绕方向如左图所示
- There shall be no dirt such as deformation phenomenon, Mantissa box fillers must be used
每箱不可有脏污, 变形现象, 尾数箱必须用填充物
- Carton material: K=K, Carton thickness: 6~7mm
纸箱材质:K=K, 纸箱厚度:6~7mm

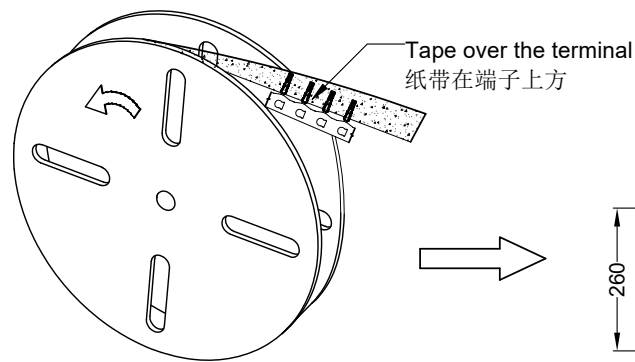

卷装方式
Package way

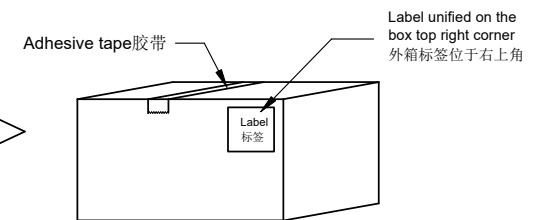
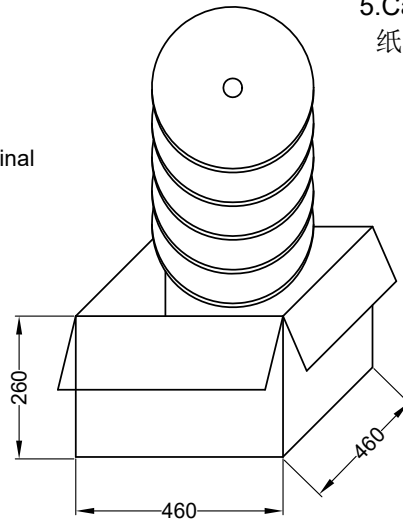

					一般公差		 东莞市思索连接器有限公司 SWB CONNECTORS CO.,LTD		料号: 1038T-PXXX-X											
					.X ±0.35				名称: 1.00mm Terminal Packing											
					.XX ±0.25															
					.XXX ±0.15				核 准		审 查		制 作		日 期					
					X° ±0.2°				Mali		2021/04/28		单 位		比 例		页 次		版 本	
日期	版次	变更编号	变更内容说明		变更人	核 准	视 角				MM		1:1		1/1		A		A-000	

RoHS

本产品符合我司QA-3-04-005
环境管理物质标准规范

包装图

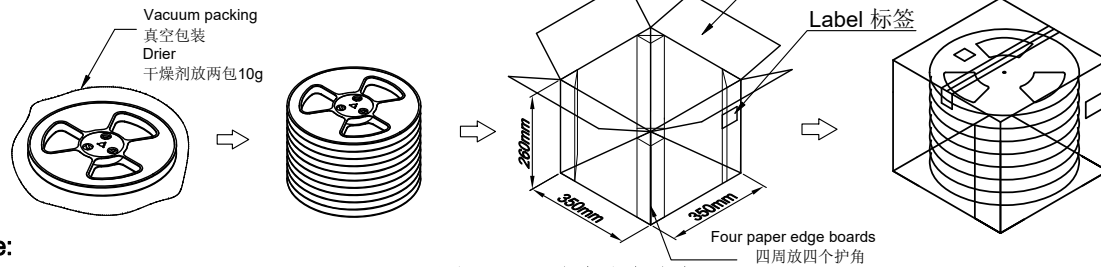
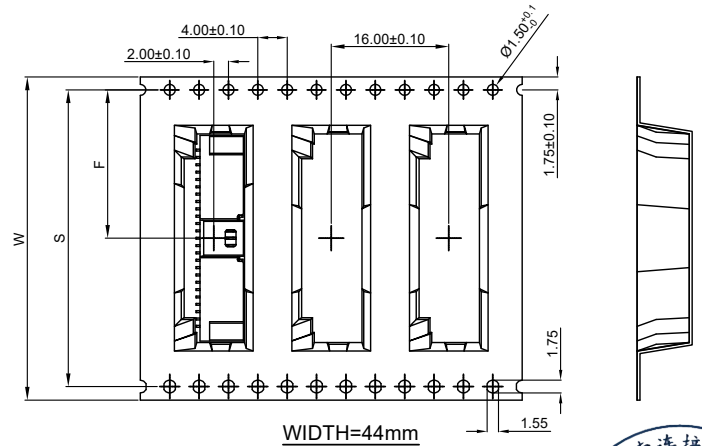
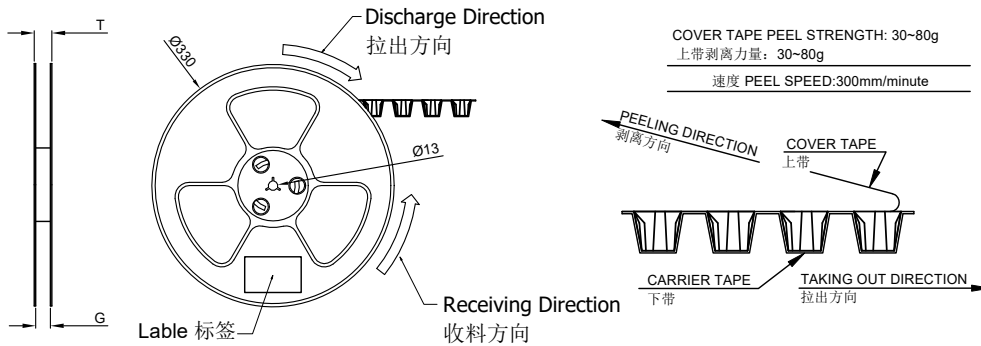
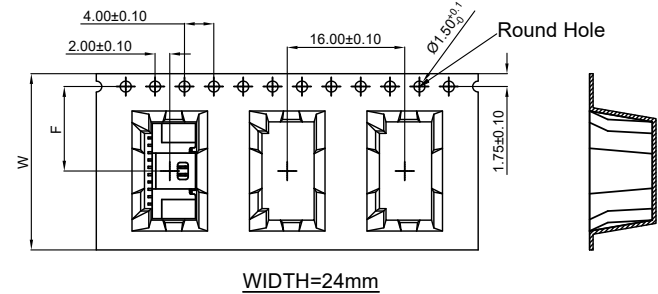
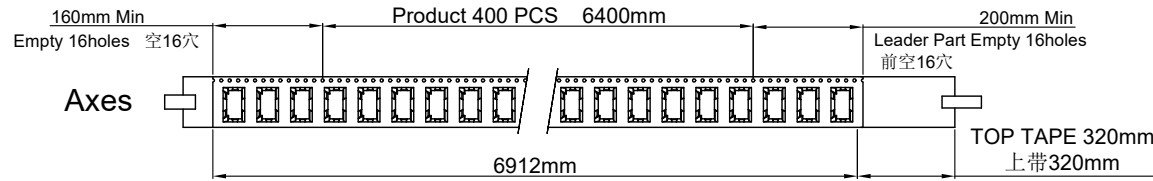

- Note:**
- Carrier Camber Is Within 1mm In 100mm ; 带长100mm内容许弯曲度1mm
 - 10 Sprocket Hole Pitch Cumulative Tolerance±0.2MM; 圆孔十个孔距离累计允许公差为±0.2mm
 - Material for PS; 材质为PS材质; Color颜色:透明色
 - bracer保护带: Color颜色:Nature透明;厚度0.40mm最小
 - Thickness=0.50±0.05; 材料厚度为0.50±0.05mm
 - Cover Tape上带: 冷封
 - Carton material纸箱材质:K=K; Carton Thickness纸箱厚度: 6~7mm

	Pin No.	W	S	F	T	G	B0	REEL /PCS	CARTON /R	CARTON /PCS
ZD1038WRS-2*XXHF 1038WRS-2*XX-4TXXXXR1	ZD1038WRS-2*08HF	24	/	11.50	29.5	24.4	10.65	400	8	3200
	ZD1038WRS-2*10HF						12.65			
	ZD1038WRS-2*12HF	32	28.4	14.2	37.5	32.4	14.65	400	6	2400
	ZD1038WRS-2*15HF						17.65			
	ZD1038WRS-2*20HF	44	40.4	20.20	49.5	44.4	22.65	400	5	2000
	ZD1038WRS-2*25HF						27.65			

						东莞市思索连接器有限公司 SWB CONNECTORS CO.,LTD		料号: PPN: 1038WRS-2*XX-4TXXXXR1 CTN: ZD1038WRS-2*XXHF				
						核准 审查 制作 日期		名称: 1.00mm Connectors 90° Packing				
日期	版次	变更编号	变更内容说明	变更人	核准	HuangTao		单位	比例	页次	版本	编号
						2021/06/18		MM	1:1	1/1	A	A-000

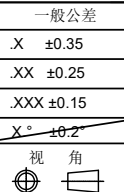

RoHS

本产品符合我司QA-3-04-005
环境管理物质标准规范

包装图

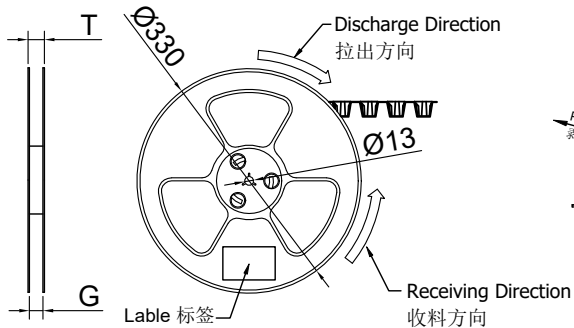
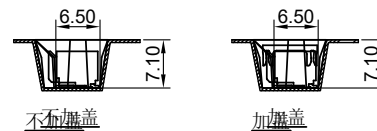
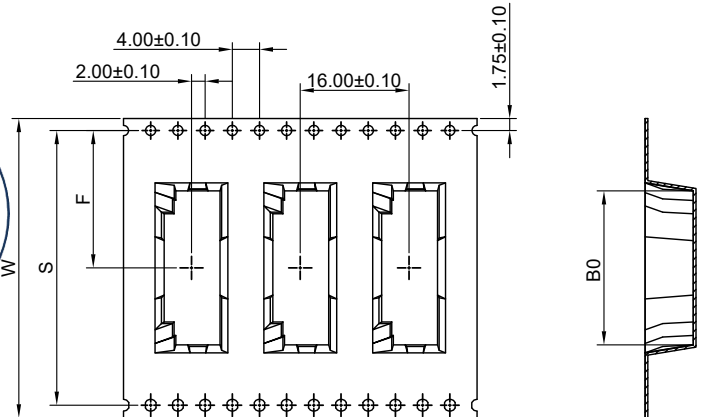
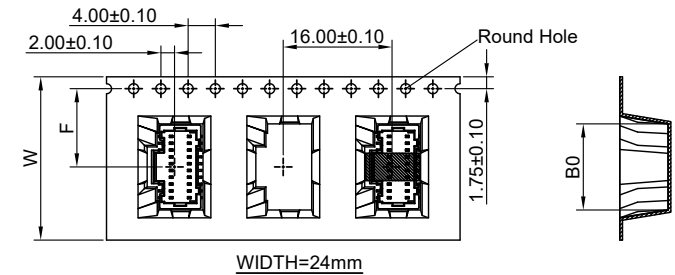
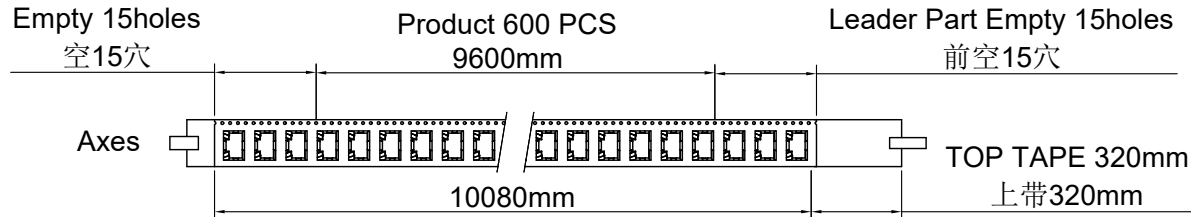

COVER TAPE PEEL STRENGTH: 30-80g
上带剥离力量: 30-80g
速度 PEEL SPEED: 300mm/minute

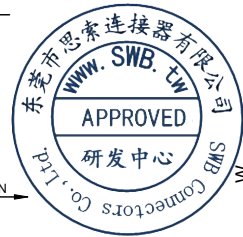
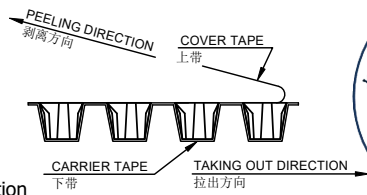

Lable 标签
Single hole: None Hole Side
单孔: 贴无链孔侧
Double hole: Elliptical Hole Side
双孔: 贴椭圆孔侧

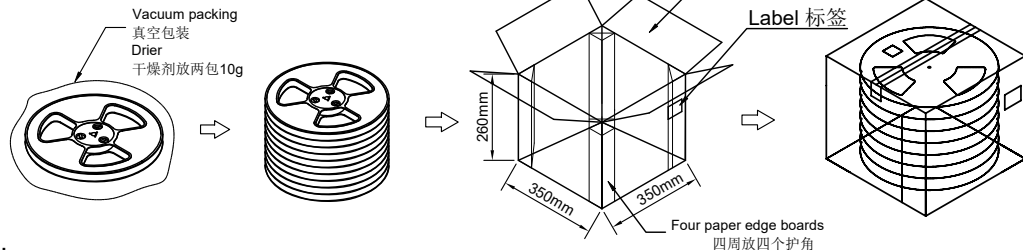

Note:

- Carrier Camber Is Within 1mm In 100mm ; 带长100mm内容许弯曲度1mm
- 10 Sprocket Hole Pitch Cumulative Tolerance±0.2MM ; 圆孔十个孔距离累计允许公差为±0.2mm
- Materiaal for PS ; 材质为PS材质; Color颜色:透明色
- bracer保护带: Color颜色:Nature透明;厚度0.40mm最小
- Thinkess=0.40±0.05 ; 材料厚度为0.40±0.05mm
- Cover Tape上带: 冷封
- Carton material纸箱材质:K=K; Carton Thickness纸箱厚度: 6~7mm

Pin No.	W	S	F	T	G	B0	REEL	CARTON	CARTON
							/PCS	/R	/PCS
ZD1038WVS-2*08HF-C	24	/	11.50	29.5	25.4	10.65	600	8	4800
ZD1004WVS-2*10HF-C						12.65			
ZD1004WVS-2*12HF-C						14.65	600	6	3600
ZD1004WVS-2*14HF-C	32	28.4	14.20	36.5	32.4	16.65			
ZD1004WVS-2*15HF-C						17.65			
ZD1004WVS-2*18HF-C						20.65	600	5	3000
ZD1004WVS-2*20HF-C	44	40.4	20.20	47.0	45.5	22.65			
ZD1004WVS-2*25HF-C						27.65			



东莞市思索连接器有限公司
SWB CONNECTORS CO.,LTD

料号: PPN: 1038WVS-2*XX-4TXXXXXX
CTN: ZD1038WVS-2*XXHF

名称:
1.00mm Connectors 180° Package

单位	比例	页次	版本	编号
MM	1:1	1/1	A	A-000

一般公差
.X ±0.35
.XX ±0.25
.XXX ±0.15
X° ±0.2°
视角

核准	审查	制作	日期
		HuangTao	2021/05/07

日期	版次	变更编号	变更内容说明	变更人	核准