

RoHS

本产品符合我司QA-3-04-005
环境管理物质标准规范

包装图

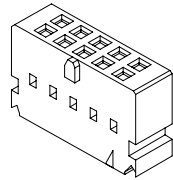

干燥剂

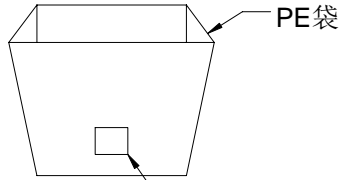

PE袋

Lable标签

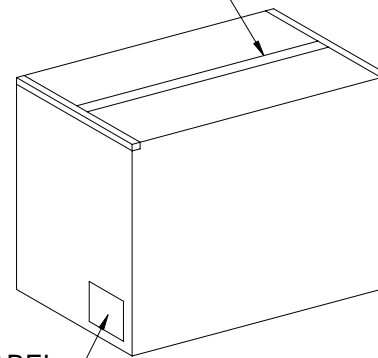
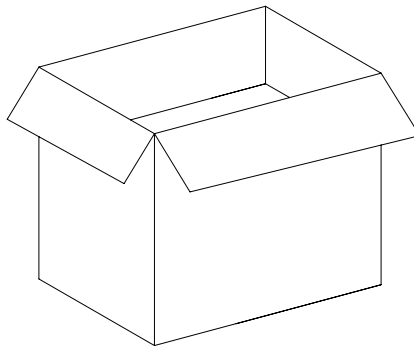

胶带ADHESIVE TAPE

标签LABEL

Note注解:

1. Put Housing in a PE bag, Packing detail see the table below
将 Housing放入PE袋内, 并放入一包干燥剂, 并将PE袋封好.贴上标签.
2. Put PE bag packed products in cartons, Packing detail see the table below
将装好产品的PE袋放入纸箱内, 详细包装见下表
3. Label depends on customer request, carton opening joint with transparent tape
标签依客户要求而定, 纸箱开口处用透明胶带贴合.



Poles	Bag PCS
2*02	1000
2*03	1000
2*04	1000
2*05	1000
2*06	1000
2*07	1000
2*08	1000
2*09	1000
2*10	1000
2*11	1000
2*12	1000
2*13	1000
2*14	1000
2*15	1000
2*16	1000

					<p>一般公差</p> <p>.X ±0.35</p> <p>.XX ±0.25</p> <p>.XXX ±0.15</p> <p>X° ±0.2°</p> <p>视角</p>				<p>东莞市思索连接器有限公司</p> <p>SWB CONNECTORS CO.,LTD</p>				<p>料号: 9555H-2*XXX-PT</p> <p>名称: 2.54mm Housing Package</p>				
2020/7/25	B		更改图框	Roy.Hu	Robing	核准	审查	制作	日期								
日期	版次	变更编号	变更内容说明	变更人	核准	Bob Sun	Jova Lau	Allen	2013/08/31	单位	比例	页次	版本	编号			
										mm	1:1	1/1	B	A-106			

RoHS

本产品符合我司QA-3-04-005
环境管理物质标准规范

包装图

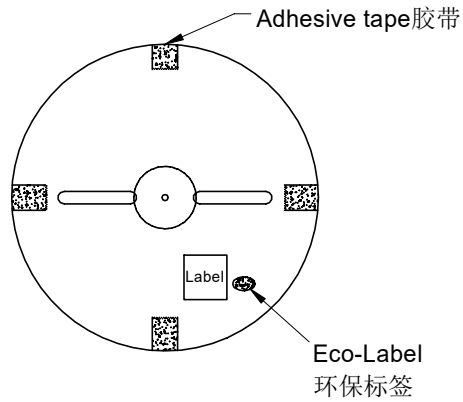

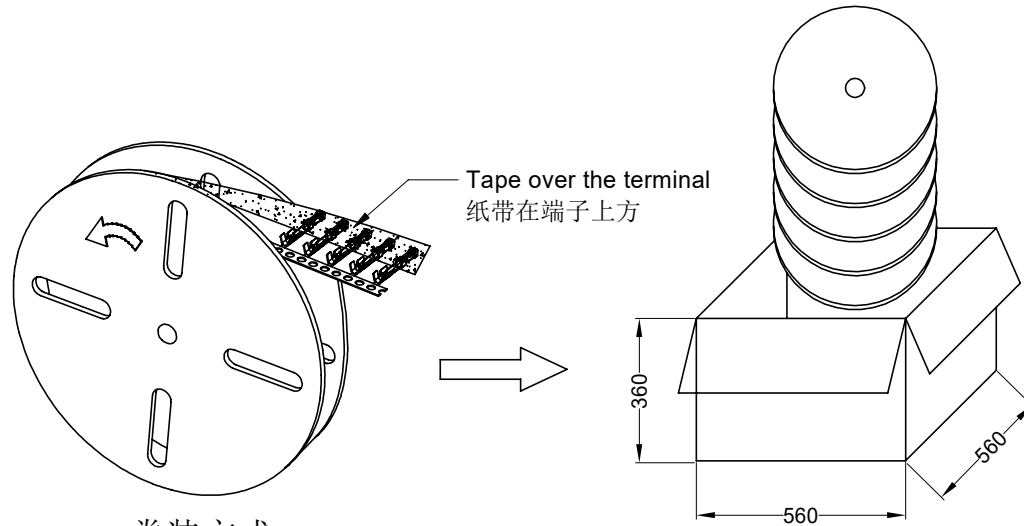

Note 注解:

- Quantity 数量:
15K PCS/REEL 一卷15K/PCS
11REEL/BOX 一箱11卷
165K PCS/BOX 一箱165K/PCS
- Each reel and outer box must be labeled and Eco-Label Respectively labeled
每盘和外箱都必须有标签及环保标签分别标示
- Terminal winding direction as shown
端子缠绕方向如左图所示
- There shall be no dirt such as deformation phenomenon, Mantissa box fillers must be used
每箱不可有脏污, 变形现象, 尾数箱必须用填充物
- Carton material: K=K, Carton thickness: 6±1mm
纸箱材质:K=K, 纸箱厚度:6±1mm

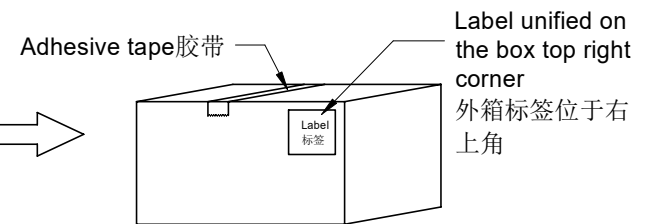

卷装方式
Package way

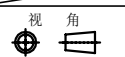

						一般公差		 东莞市思索连接器有限公司 SWB CONNECTORS CO.,LTD		料 号: 9555T-PXX-A				
2020/07/25	C	更改图框		Roy.Hu	Robing	.X ±0.35	核 准 审 查 制 作 日 期			名 称: 2.54mm Terminal Packing				
2019/03/14	B	ER20190314002	依实际装箱修改纸箱大小		Joshua	Smark			.XX ±0.25	 视 角		单位	比例	页次
日期	版次	变更编号	变更内容说明		变更人	核 准	.XXX ±0.15	Allen 2013/09/29				mm	1:1	1/1

RoHS

本产品符合我司QA-3-04-005
环境管理物质标准规范

包装图

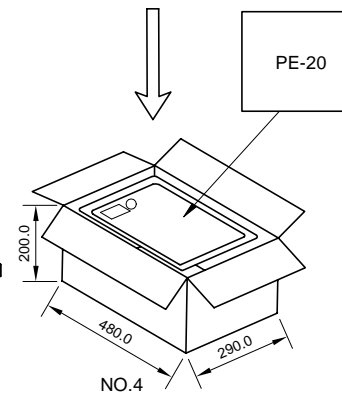
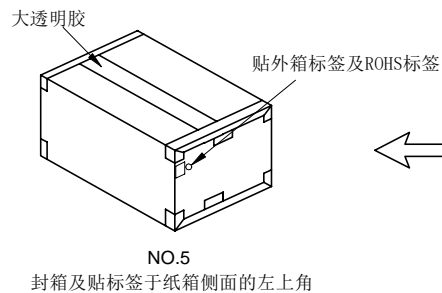
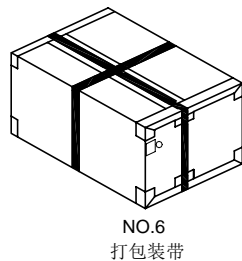
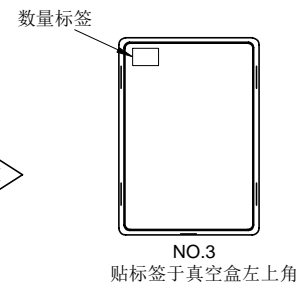
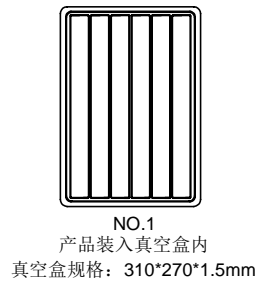
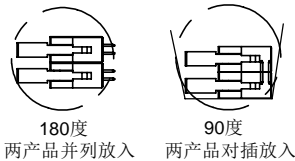

2.54牛角 (180度&90度)		
规格	真空盒 装数量	整箱装 总数量
2*03P	180	1620
2*04P	168	1512
2*05P	156	1404
2*07P	132	1188
2*08P	120	1080
2*10P	108	972
2*12P	96	864
2*13P	96	864
2*15P	84	756
2*17P	72	648
2*20P	60	600
2*25P	60	540
2*30P	48	432
2*32P	48	432

说明:

- 1、产品如图所示型态放入吸塑盘;
- 2、注意各标签样式, 位置及方向的一致性;

					<p>一般公差</p> <p>.X ±0.35</p> <p>.XX ±0.25</p> <p>.XXX ±0.15</p> <p>X° ±0.2°</p> <p>视角</p>				<p>东莞市思索连接器有限公司</p> <p>SWB CONNECTORS CO.,LTD</p>				<p>料号: 9555WV-2*XXA-PXXX</p>			
					<p>核准</p> <p>审查</p> <p>制作</p> <p>日期</p>				<p>名称:</p> <p>2.54mm Connectors 180° Package</p>							
2020/08/11	B		变更图框	Roy	Robing					单位	比例	页次	版本	编号		
日期	版次	变更编号	变更内容说明	变更人	核准	Mandy				mm	1:1	1/1	B	A-195		