

RoHS

This products can apply to the SWB Doc NO. QA-3-04-005 of Environmental&Material Management Rules

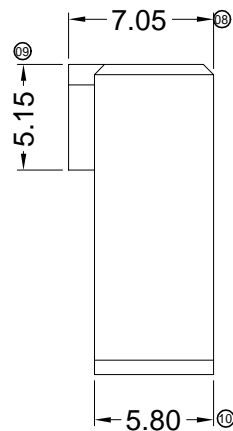
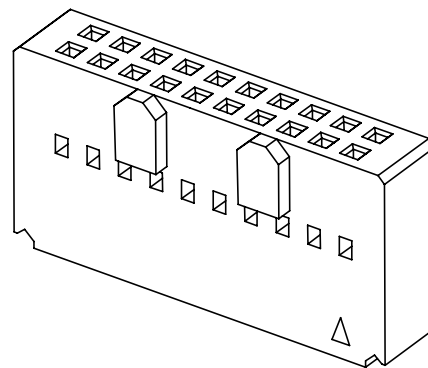
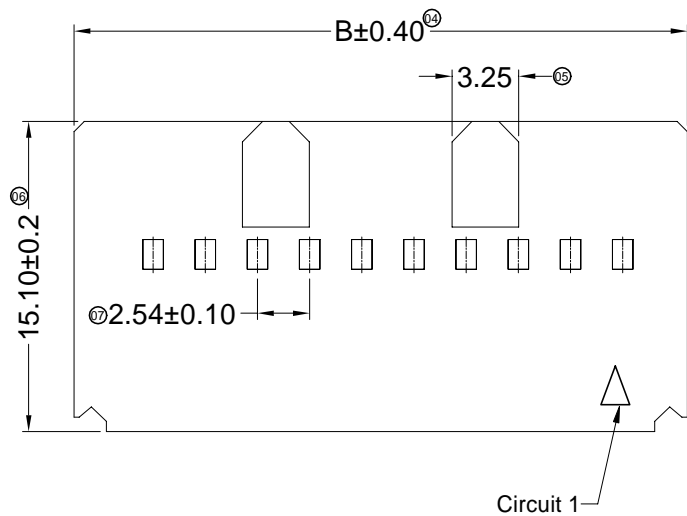
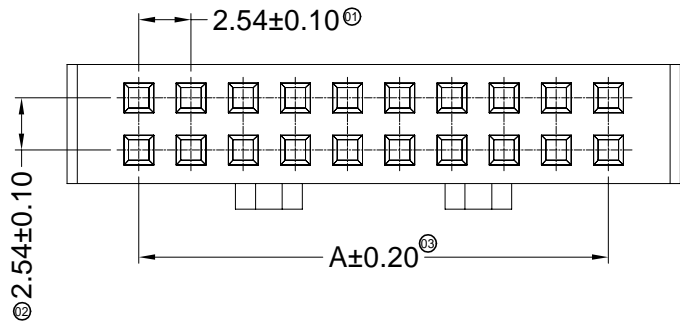

■ Specifications :

- Voltage rating: 250V AC / DC
- Current rating: 3A AC / DC
- Withstanding voltage: 1500V AC/minute
- Temperature range: -25°C~+85°C
- Insulation resistance: ≥1000MΩ
- Contact resistance: ≤20mΩ
- After environmental testing: ≤30mΩ
- Suitable SWB Terminal: 9555T-A
- Mates With SWB Wafer: 9555W

9555 H X-2*XX B2-PT XX

① ② ③ ④ ⑤ ⑥ ⑦

- ① Series No.
- ② Category: H-HSG
- ③ Welding Board Angle: Blank-ordinary
- ④ Row No.-Pin No.: 2*XX-2*02P~2*32P
- ⑤ Special No.: B2-Double convex
- ⑥ Material: PT-PBT 94V-0
- ⑦ Color: Blank-Natural Color

Poles	Dimensions (mm)		Poles	Dimensions (mm)		Poles	Dimensions (mm)	
	A	B		A	B		A	B
2*02	2.54	9.54	2*13	30.48	37.48	2*24	58.42	65.42
2*03	5.08	12.08	2*14	33.02	40.02	2*25	60.96	67.96
2*04	7.62	14.62	2*15	35.56	42.56	2*26	63.50	70.50
2*05	10.16	17.16	2*16	38.10	45.10	2*27	66.04	73.04
2*06	12.70	19.70	2*17	40.64	47.64	2*28	68.58	75.58
2*07	15.24	22.24	2*18	43.18	50.18	2*29	71.12	78.12
2*08	17.78	24.78	2*19	45.72	52.72	2*30	73.66	80.66
2*09	20.32	27.32	2*20	48.26	55.26	2*31	76.20	83.20
2*10	22.86	29.86	2*21	50.80	57.80	2*32	78.74	85.74
2*11	25.40	32.40	2*22	53.34	60.34			
2*12	27.94	34.94	2*23	55.88	62.88			

2020/07/31	E		Update Drawing Frame	Roy	Robing
2015/05/13	D		Modify drawing frame format	jian.He	
2013/08/06	C		Modify drawing frame format	Luna	
DATE	REV	ECN NO	DESCRIPTION	MODIFY	APPROVAL

GENERAL TOLERANCE
.X ±0.35
.XX ±0.25
.XXX ±0.15
X.° ±2°
PROJECT
⊕
⊖



东莞市思索连接器有限公司
SWB CONNECTORS CO.,LTD

APPROVAL	CHECK	DRAWN	DATE
Smark	Guo	Liu Yan	2007/05/03

PART NO. 9555H-2*XXB2-PT				
TITLE 2.54 mm Crimp Style Connectors				
UNIT	SCALE	SHEET	REV	NUMBER
mm	1:1	1/1	E	A-053

RoHS

This products can apply to the SWB Doc NO. QA-3-04-005 of Environmental&Material Management Rules

■ Specifications :

- Voltage rating: 250V AC / DC
- Current rating: 3A AC / DC
- Withstanding voltage: 1500V AC/minute
- Temperature range: -25°C~+85°C
- Insulation resistance:≥1000MΩ
- Contact resistance: ≤20mΩ
- After environmental testing: ≤30mΩ
- Suitable SWB Terminal:9555T-A
- Mates With SWB Wafer: 9555W

F
E
D
C
B
A

F
E
D
C
B
A

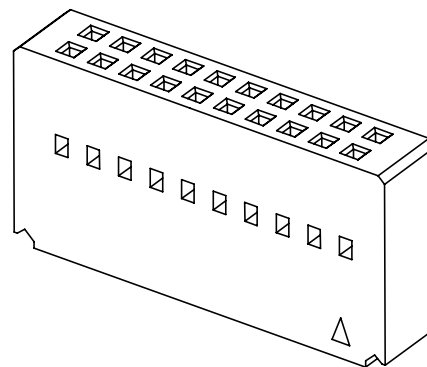
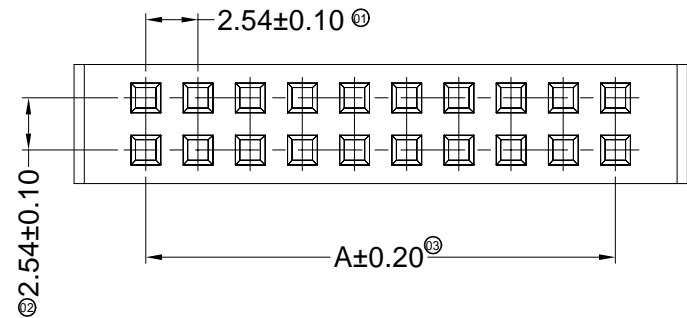

9555 H X-2*XX B-PT XX

① ② ③ ④ ⑤ ⑥ ⑦

- ① Series No.
- ② Category: H-HSG
- ③ Welding Board Angle: Blank-ordinary
- ④ Row No.-Pin No.: 2*XX-2*02P~2*32P
- ⑤ Special No.: B-Single gap
- ⑥ Material: PT-PBT 94V-0
- ⑦ Color: Blank-Natural Color

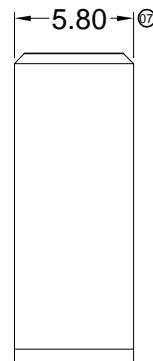
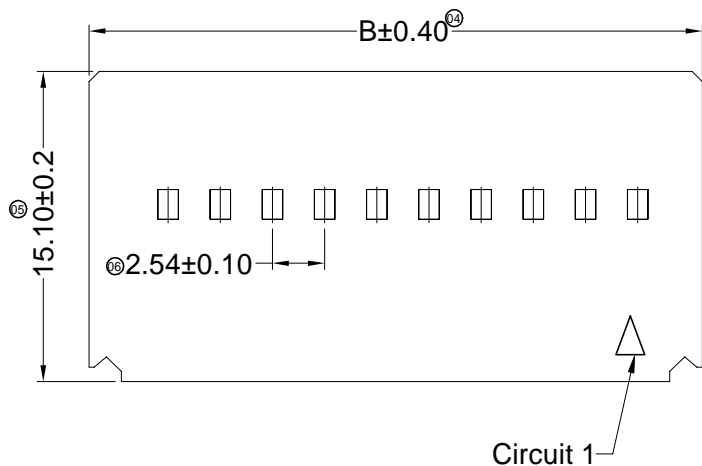

Poles	Dimensions (mm)		Poles	Dimensions (mm)		Poles	Dimensions (mm)	
	A	B		A	B		A	B
2*02	2.54	9.54	2*13	30.48	37.48	2*24	58.42	65.42
2*03	5.08	12.08	2*14	33.02	40.02	2*25	60.96	67.96
2*04	7.62	14.62	2*15	35.56	42.56	2*26	63.50	70.50
2*05	10.16	17.16	2*16	38.10	45.10	2*27	66.04	73.04
2*06	12.70	19.70	2*17	40.64	47.64	2*28	68.58	75.58
2*07	15.24	22.24	2*18	43.18	50.18	2*29	71.12	78.12
2*08	17.78	24.78	2*19	45.72	52.72	2*30	73.66	80.66
2*09	20.32	27.32	2*20	48.26	55.26	2*31	76.20	83.20
2*10	22.86	29.86	2*21	50.80	57.80	2*32	78.74	85.74
2*11	25.40	32.40	2*22	53.34	60.34			
2*12	27.94	34.94	2*23	55.88	62.88			

2020/07/31	E		Update Drawing Frame	Roy	Robing
2015/05/13	D		Modify drawing frame format	jian.He	
2013/08/06	C		Modify drawing frame format	Luna	
DATE	REV	ECN NO	DESCRIPTION	MODIFY	APPROVAL

GENERAL TOLERANCE	
.X	±0.35
.XX	±0.25
.XXX	±0.15
X.°	±2°
PROJECT	
⊕	⊖



东莞市思索连接器有限公司
SWB CONNECTORS CO.,LTD

APPROVAL	CHECK	DRAWN	DATE
Smark	Guo	Liu Yan	2007/05/03

PART NO. 9555H-2*XXB-PT				
TITLE 2.54 mm Crimp Style Connectors				
UNIT	SCALE	SHEET	REV	NUMBER
mm	1:1	1/1	E	A-053

1 2 3 4 5 6 7 8

RoHS

This products can apply to the SWB Doc NO. QA-3-04-005 of Environmental&Material Management Rules



Specifications :

- Voltage rating: 250V AC / DC
- Current rating: 3A AC / DC
- Withstanding voltage: 1500V AC/minute
- Temperature range: -25°C~+85°C
- Insulation resistance: ≥1000MΩ
- Contact resistance: ≤20mΩ
- After environmental testing: ≤30mΩ

9555 T X-P XX X-A

① ② ③ ④ ⑤ ⑥ ⑦

- ① Series Number
- ② Category: T-terminal
- ③ Shape: Blank-ordinary
- ④ Material: P-Phosphor bronze
- ⑤ Plating Code: V**-All Gold-Plated, G-Gold-Plated Contact, *01-Gold Flash ; *03-3u" ; *05-5u" ; *15-15u" ; *30-30u" ; SN-Bright tin plating
- ⑥ Plating method: Blank-Stamping before plating
- ⑦ Mold No./Mark/Special No. A-matching 9555H-2*XX HSG

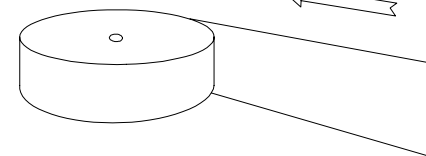

Receiving direction map after Plated (Crimp opening outwards)

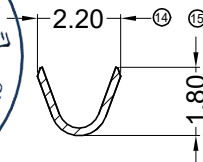
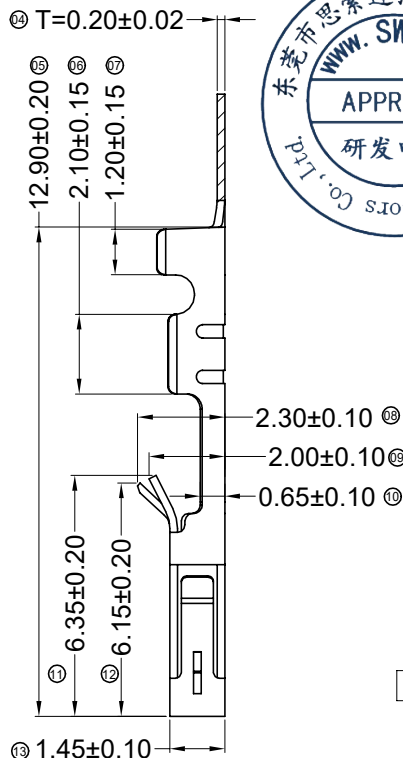
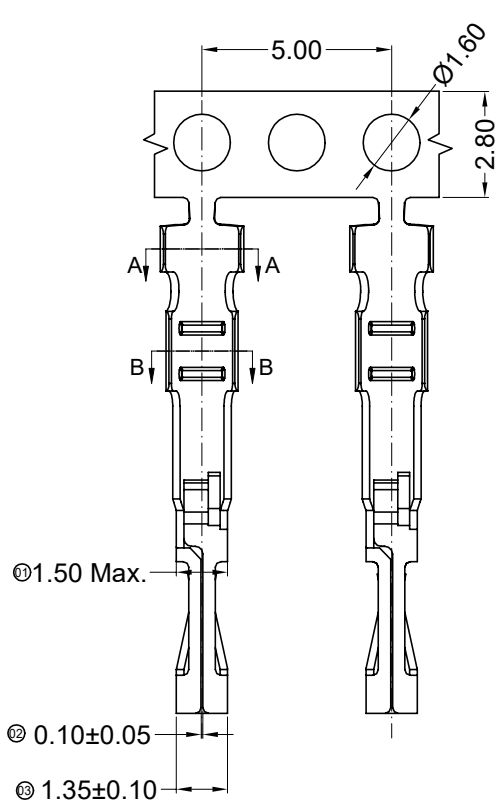

SECTION: A-A SCALE: 1:1

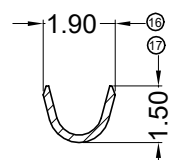

SECTION: B-B SCALE: 1:1

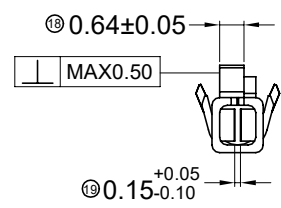

9555T-PG15-A	Phosphor Bronze	AWG#22-30	Stamping Before Pating:30u" Ni;Contact Area gold:15u" Min.	9555H
9555T-PG03-A			Stamping Before Pating:30u" Ni;Contact Area gold:3u" Min.	
9555T-PG01-A			Stamping Before Pating:30u" Ni;Contact Area Gold Flash	
9555T-PSN-A			Stamping Before Plating:30u" Ni;70u"Sn	
PART NO	Material	Wire Range	Finish	Used In SWB Housing

2020/07/22	H		Update Drawing Frame	Roy.Hu	Robing
2015/05/14	G		Modify drawing frame format	jian.He	Success
2013/12/12	F		Change ⑧⑩⑫ Size	Luna	Success
DATE	REV	ECN NO	DESCRIPTION	MODIFY	APPROVAL

GENERAL TOLERANCE
.X ±0.35
.XX ±0.25
.XXX ±0.15
X.° ±2°
PROJECT
⊕ ⊖

东莞市思索连接器有限公司
SWB CONNECTORS CO.,LTD
 APPROVAL: Success, CHECK: Sun Kaibao, DRAWN: Song Li, DATE: 2013/07/04

PART NO. 9555T-PXX-A				
TITLE: 2.54 mm Crimp Style Connectors				
UNIT	SCALE	SHEET	REV	NUMBER
mm	1:1	1/1	H	A-014

RoHS

This products can apply to the SWB Doc NO. QA-3-04-005 of Environmental&Material Management Rules



Specifications :

- Voltage rating: 250V AC / DC
- Current rating: 3A AC / DC
- Withstanding voltage: 1500V AC/minute
- Temperature range: -25°C~+85°C
- Insulation resistance: ≥1000MΩ
- Contact resistance: ≤20mΩ
- After environmental testing: ≤30mΩ

9555 W V XX- 2*XX B-6T V01 XX

① ② ③ ④ ⑤ ⑥ ⑦ ⑧ ⑨

- ① Series No.
- ② Category: W-wafer
- ③ Welding Board Angle: V-180°
- ④ Welding Way: Blank-DIP
- ⑤ Row No.-Pin No.: 2*XX-Double row
- ⑥ Special No.:
B-DIP=4.10mm Total Length=18.30mm
- ⑦ Material: 6T-PA6T 94V-0
- ⑧ Planting Category:
V**:All Gold-Plated G**:Gold-Plated Contact
*01-Gold Flash ; *02-2u" ; *03-3u" ; *05-5u"
*10-10u" ; *15-15u" ; *30-30u" ; *50-50u"
SN-Bright tin plating 70u"
SN1-Bright tin plating 120u"Min. ;
SW-Fog Tin plating
- ⑨ Color: Blank-natural color

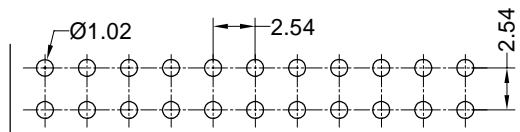
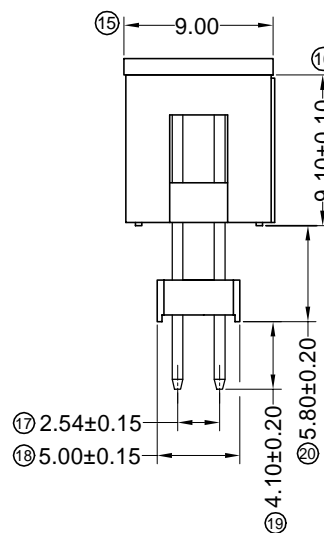
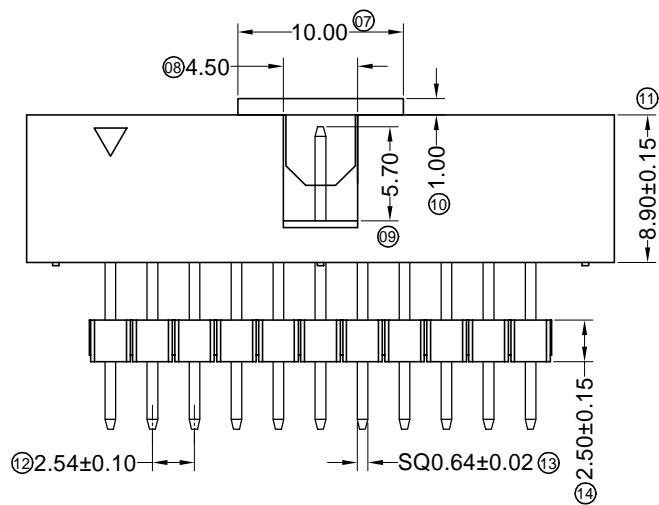
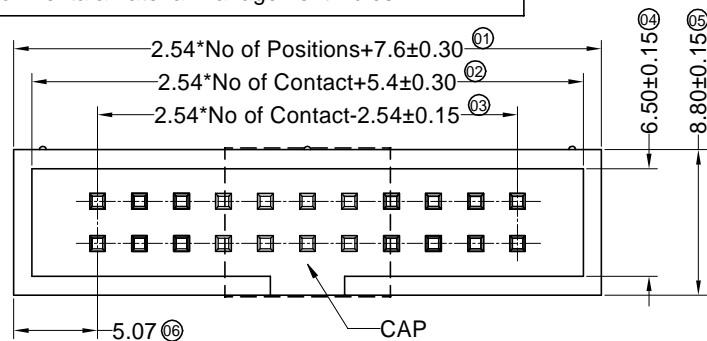

P.C.B LAYOUT

9555WV-2*XXB-6TV01	Nylon 6T UL 94V-0	Brass	Gold-Flash	9555H
PART NO	Material	Material(Pin)	Finish(Pin)	Mates With SWB Housing

DATE	REV	ECN NO	DESCRIPTION	MODIFY	APPROVAL	GENERAL TOLERANCE	APPROVAL				PART NO.	TITLE			
2020/08/10	C		Update Drawing Frame	Roy	Robing	.X ±0.35	东莞市思索连接器有限公司 SWB CONNECTORS CO.,LTD	APPROVAL	CHECK	DRAWN	DATE	9555WV-2*XXB-6TV01	2.54mm Crimp Style Connectors		
2015/05/14	B		Modify drawing frame format	jian.He	.XX ±0.25	UNIT						SCALE	SHEET	REV	NUMBER
						X.XX ±0.15						mm	1:1	1/1	C
						X.° ±2°	PROJECT	Bob Sun	Jova Lau	Sylvia	2013/11/26				

RoHS

This products can apply to the SWB Doc NO. QA-3-04-005 of Environmental&Material Management Rules

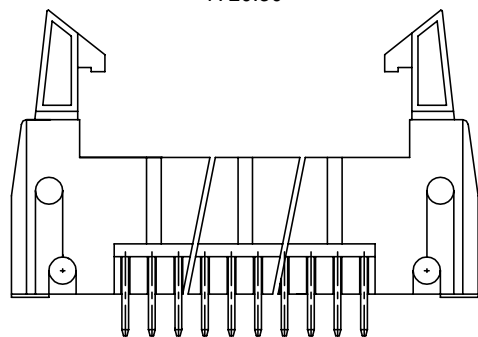
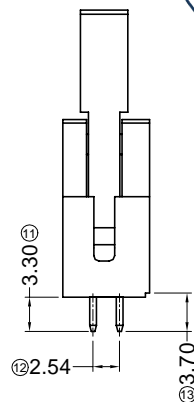
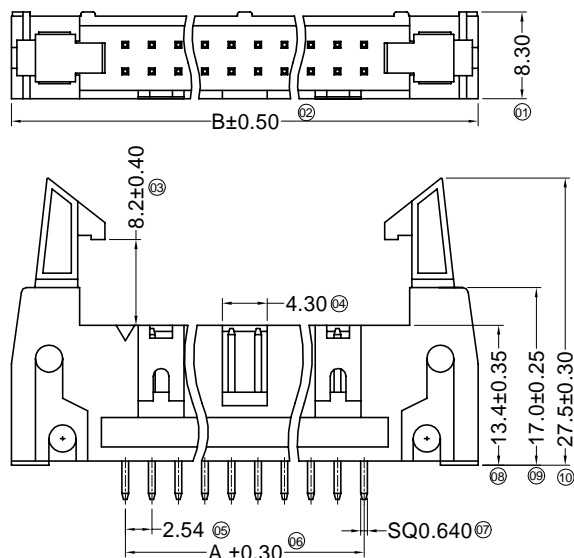

Recommended P.C.B Layout
General Tolerance±0.05

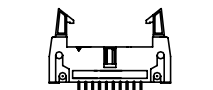

(20.24.26.30.34.40.50 Pin)

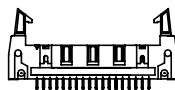

(60.64 Pin)

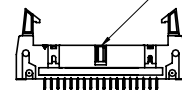

(64 Pin)

特殊64P 1Key

Specifications :

- Voltage rating: 250V AC / DC
- Current rating: 3A AC / DC
- Withstanding voltage: 500V AC/minute
- Temperature range: -40°C~+105°C
- Insulation resistance: ≥1000MΩ
- Contact resistance: ≤20mΩ
- After environmental testing: ≤30mΩ
- Material(Pin): Brass

9555 W V X-2*XX A-PT V01 XX

① ② ③ ④ ⑤ ⑥ ⑦ ⑧ ⑨

- ① Series No.
- ② Category: W-wafer
- ③ Welding Board Angle: V- Straight 180°
- ④ Welding Way: Blank-DIP
- ⑤ Row No.-Pin No.: 2*XX-2*03P~2*32P
- ⑥ Special No.: A-Ejector Header
- ⑦ Material: PT-PBT 94V-0
- ⑧ Planting Category: V01-All Gold Flash
- ⑨ Color: Blank-natural color

Poles	Dimensions (mm)		Poles	Dimensions (mm)	
	A	B		A	B
2*03P	5.08	26.82	2*12P	27.94	49.68
2*04P	7.62	29.36	2*13P	30.48	52.22
2*05P	10.16	31.90	2*15P	35.56	57.30
2*06P	12.70	34.44	2*17P	40.64	62.38
2*07P	15.24	36.98	2*20P	48.26	70.00
2*08P	17.78	39.52	2*25P	60.96	82.70
2*09P	20.32	42.06	2*30P	73.66	95.40
2*10P	22.86	44.60	2*32P	78.74	100.48

GENERAL TOLERANCE

- .X ±0.35
- .XX ±0.25
- .XXX ±0.15
- X.° ±2°

PROJECT



东莞市思索连接器有限公司
SWB CONNECTORS CO.,LTD

PART NO.
9555WV-2*XXA-PTV01

TITLE
2.54mm Box Header Style Connectors

UNIT	SCALE	SHEET	REV	NUMBER
mm	1:1	1/1	B	A-195

DATE	REV	ECN NO	DESCRIPTION	MODIFY	APPROVAL
2020/08/10	B		Update Drawing Frame	Roy	Robing

APPROVAL	CHECK	DRAWN	DATE
Smark	Alan qin	Mandy	2018/07/25

RoHS

This products can apply to the SWB Doc NO. QA-3-04-005 of Environmental&Material Management Rules

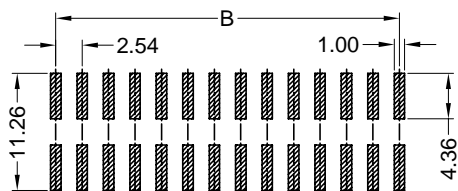
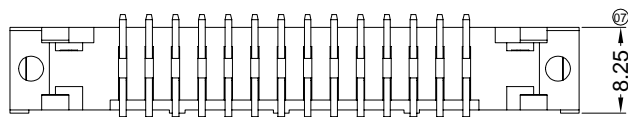
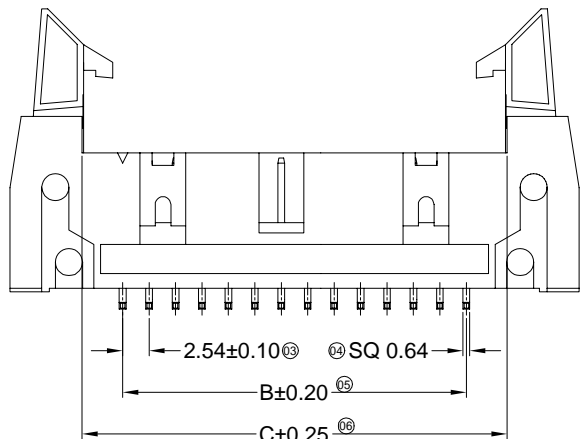
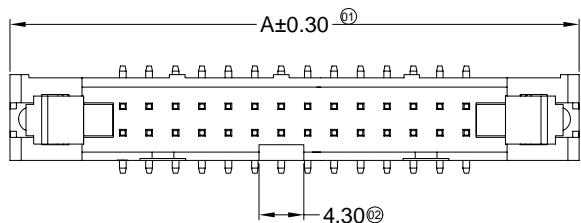

Recommended P.C.B Layout
General Tolerance±0.05

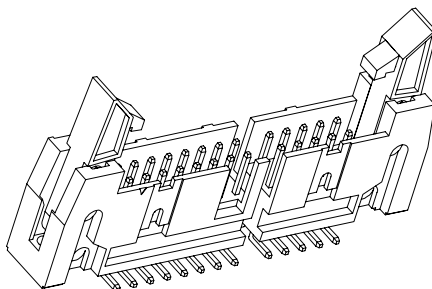
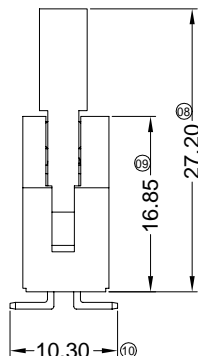

■ Specifications :

- Voltage rating: 250V AC / DC
- Current rating: 3A AC / DC
- Withstanding voltage: 1500V AC/minute
- Temperature range: -25°C~+85°C
- Insulation resistance: ≥1000MΩ
- Contact resistance: ≤20mΩ
- After environmental testing: ≤30mΩ

9555 W V S-2*XX A-PT V01 XX

① ② ③ ④ ⑤ ⑥ ⑦ ⑧ ⑨

- ① Series No.
- ② Category: W-wafer
- ③ Welding Board Angle: V- Straight 180°
- ④ Welding Way: S-SMT
- ⑤ Row No.-Pin No.: 2*XX-2*02P~2*32P
- ⑥ Plug the Pin & Special No.: A-Ejector Header
- ⑦ Material: PT-PBT 94V-0
- ⑧ Planting Category: V01-All Gold Flash
- ⑨ Color: Blank-natural color

Poles	Dimensions (mm)			Poles	Dimensions (mm)		
	A	B	C		A	B	C
2*05	31.90	10.16	18.00	2*15	57.40	35.56	43.40
2*06	34.60	12.70	20.54	2*17	62.38	40.64	48.48
2*07	36.98	15.24	23.08	2*20	70.00	48.26	56.10
2*08	39.52	17.78	25.62	2*25	82.70	60.96	68.80
2*10	44.60	22.86	30.70	2*30	95.60	73.66	81.82
2*12	49.68	27.94	35.78	2*32	100.70	78.74	86.90
2*13	52.15	30.48	38.32				

9555WVS-2*XXA-PTV01	PBT UL 94V-0	Brass	Gold-Flash	9555H
PART NO	Material	Material(Pin)	Finish(Pin)	Mates With SWB Housing

2020/08/11	E		Update Drawing Frame	Roy	Robing
2015/05/14	D		Modify drawing frame format	jian.He	
2013/08/19	C	ECN2013082501	Modify drawing frame format	Luna	
DATE	REV	ECN NO	DESCRIPTION	MODIFY	APPROVAL

GENERAL TOLERANCE
.X ±0.35
.XX ±0.25
.XXX ±0.15
X.° ±2°
PROJECT
⊕
⊖



东莞市思索连接器有限公司
SWB CONNECTORS CO.,LTD

APPROVAL	CHECK	DRAWN	DATE
		Liu Yan	2007/05/03

PART NO. 9555WVS-2*XXA-PTV01				
TITLE 2.54 mm Crimp Style Connectors				
UNIT	SCALE	SHEET	REV	NUMBER
mm	1:1	1/1	E	A-012